

---

## MULTIROBOTIC SYSTEM FOR EDUCATION

*Ing. Vladimír Baláž Ph.D.*

*Department of Manufacturing Machinery and Robotics,  
Technical University  
(Košice, Slovakia)*

*The contribution describes a design of automated robotized system for education with robot OTC suited for manipulation and robot Motoman that provides assembling of chosen parts. The transport of every part is realized from / to stock through conveyor belt Bosch. Superior control system is equipped by computer with visualization program of whole workplace.*

**Keywords:** *robotic system, robot, assembly.*

### INTRODUCTION

The solutions of many problems emerging in production process require a deployment of more robots in present times. Particularly touch in to assembly of complex parts, welding of longer parts etc. Application of more robots at workplace requires a perfect prepare at design area also like at programmed equipment robots area. In operation with more robots is mainly important to avoid their mutual collisions. As solution for these situations are preferred to use off-line system program at programming at robots.

### MULTIROBOTIC SYSTEM

Automated robotized system is designed in CAD program. The workplace for manipulation is situated around conveyor belt Bosch. Every object for assembling is transported to required position at pallet. Every pallet is equipped by RFID element MDT-2K for entry of information. At loading up of object to pallet is through transmitter ID-40 activated a memory MDT-2K and writes data, which determines, where pallet stops and what kind of operation follows at object. The control of conveyor belt is realized by PLC Simatic S7/300 DP. To profibus is connected to RFID elements ID-40 for writing and reading information from memories at pallets. Change direction of pallet movement at conveyor belt is possible by transport units. Conveyor belt is equipped by inductive sensors for monitoring of pallet movement. At places, where is necessary stops the pallet are situated pneumatic stopper, which prevent to their any movement. Pneumatic stopper is fitted by inductive sensor for pallet monitoring at exactly place. The workplace for manipulation is realized with assembling robot by addition of RFID element ID-40, that after reading of information from pallet determines, if objects continue to assembly, or continue at conveyor belt.

The workplace is situated with two robots. Robot OTC Daihen AX-V6 is situated for loading up from stock to pallet that are designed to assembly or storing of finished products to stock. Searching of objects at stock is realized through barcodes. Robot OTC has six degrees of freedom that allows good reachability in envelope to arbitrary point in space. Function of effector is secured by pneumatic two-fingered gripper. Control of robot is realized through control system AX-C with input / output unit and 32 inputs / outputs. Accuracy of robot is 0,08mm that is sufficient for manipulation with chosen objects.

The second one robot is situated to assembly. Robot Motoman SDA 10F is dual arm robot with 15-teen degrees of freedom. Each arm of robot can be loaded at flange

by weight 10kg. For assembly purpose is one of arm equipped by two-fingered gripper and second one by three-fingered pneumatic gripper To control of robot was designed control system FS100, where is touch screen programmed unit (pendant) connect. Control system FS100 is equipped by input / output card that allows connecting 16 inputs and 16 outputs.

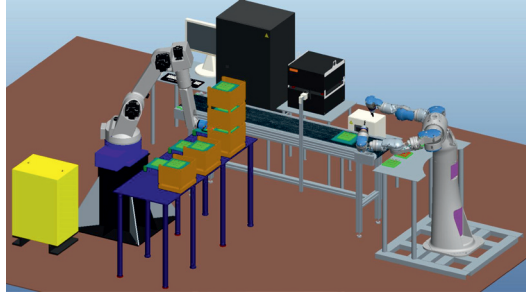

Fig. 1. Design of workplace in CAD system

Design of workplace with conveyor belt tray is on Fig. 1. Workplace contains also a superior control system and camera system Omron 150 with two cameras. This camera system allows determining most effective method for off take objects from pallet. Whole automated robotized workplace is controlled by superior control system on PLC base components. At Fig.2 is presented basic flowchart for information flow of workplace.

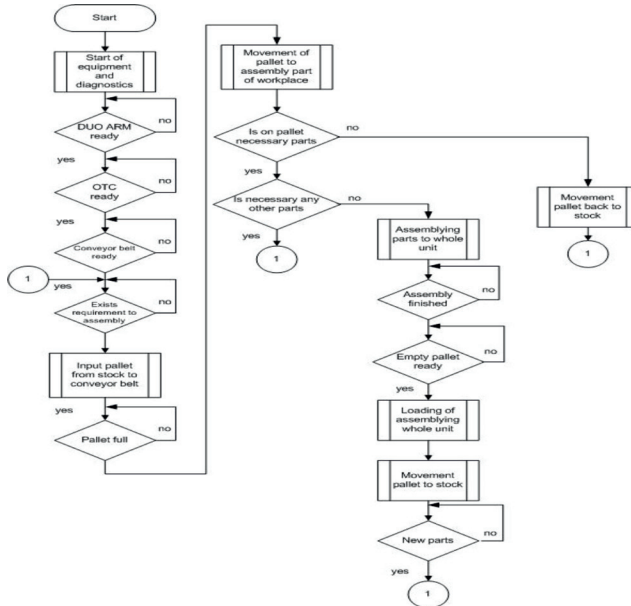

Fig. 2. Basic flowchart for information flow of workplace

Block diagram for transmission of information at workplace is on Fig.3.

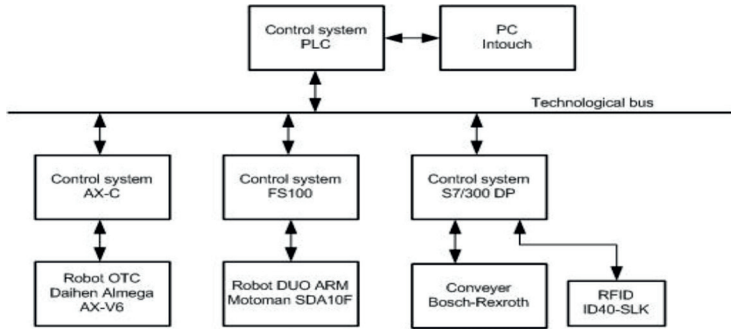

Fig. 3. Block diagram for transmission of information at workplace

## CONCLUSION

Automated robotized system is built to verification purpose for behavior of robots designed in more numbers at one workplace. The workplace is built gradually and first phase of solution in present time. Assembling part of workplace will be used for recognition of non-oriented objects through camera system that rapidly increases the possibilities at workplace.

Contribution was created under projects VEGA 1/0810/11 Princípy profilácie a kooperácie multirobotických systémov

## REFERENCES

1. Buda, J., Kováč, M.: Projektovanie a prevádzka robotizovaných systémov. Bratislava: TU, 1990. 335 s. ISBN 80-05-00680-2
2. Sukop M., Hajduk M., Varga J., Vagaš M.: Increasing degree of automation of production systems based on intelligent manipulation, Acta Mechanica Slovaca, roč. 15, č.4, 2011, ISSN 1335-2393
3. Hajduk, M, Baláž, V, Sukop, M, Evin, M, Vagaš, M.: Robotized Cell for Palletization with CCD Camera, IN: Optirob 2007: Bren Publishing House, ISBN 9789736486562