

ARTICLE

Study Of The Formation Conditions Of Aluminum Oxide Nanoparticles In An Overstressed Nanosecond Discharge Between Aluminum Electrodes In A Mixture Of Nitrogen And Oxygen

A.K. Shuaibov* A.Y. Minya A.A. Malinina A.N. Malinin Z.T. Gomoki V.V. Danylo
Yu.Yu. Bilak

Uzhgorod National University, st. Voloshin, 54, 88000, Uzhgorod

ARTICLE INFO

Article history

Received: 9 October 2019

Accepted: 29 October 2019

Published Online: 30 November 2020

Keywords:

Electrical and optical characteristics of plasma

Luminescence of nanostructures

Aluminum oxide

Overstressed nanosecond discharge

Nitrogen

Oxygen

ABSTRACT

The results of the study of oscillograms of voltage, current, pulsed electric power and energy input into the plasma of an overstressed nanosecond discharge between aluminum electrodes in argon and mixtures of nitrogen with oxygen (100-1) at pressures in the range of 13.3-103.3 kPa are presented, the emission plasma spectra are studied. It is shown that in mixtures of nitrogen with oxygen at atmospheric pressure, nanoparticles of aluminum oxide (Al₂O₃) are formed, the luminescence of which manifests itself in the spectral range of 200-600 nm and which is associated with the formation of F-, F + - centers and more complex aggregate formations based on oxygen vacancies. Calculations of the electron-kinetic coefficients of plasma, transport characteristics, such as mean electron energies in the range 5.116-13.41 eV, are given. The electron concentration was $1.6 \cdot 10^{20} \text{ m}^{-3}$ - $1.1 \cdot 10^{20} \text{ m}^{-3}$ at a current density of $5.1 \cdot 10^6 \text{ A / m}^2$ and $1.02 \cdot 10^7 \text{ A / m}^2$ on the surface of the electrode of the radiation source ($0.196 \cdot 10^{-4} \text{ m}^2$). Also drift velocities, temperatures and concentrations of electrons, specific losses of the discharge power for elastic and inelastic processes of collisions of electrons per unit of the total concentration of the mixture from the reduced electric field strength (E / N) for a mixture of aluminum, nitrogen, oxygen, rate constants of collisions of electrons with aluminum atoms on the E / N parameter in plasma on a mixture of aluminum vapor, oxygen and nitrogen = 30: 1000: 100000 Pa at a total mixture pressure of P = 101030 Pa are given.

1. Introduction

In works ^[1,2], the results of studying the kinetics of processes in a heterogeneous plasma based on mixed flows of a buffer gas - argon, an oxidizer (water molecules), and aluminum dust are presented. Plasma of various types of discharge (glow, pulsed and combined)

in gas-vapor mixtures of argon, water, and aluminum dust was studied. In the plasma under study, aluminum dioxide is formed at the high-voltage electrode in the form of a developed flaky surface, and thermal energy is released ^[1]. The cost of producing a hydrogen molecule in such a reactor does not exceed 1.5 eV / molecule, which is much more economical than the hydrolysis method for produc-

*Corresponding Author:

A.K. Shuaibov,

Uzhgorod National University, st. Voloshin, 54, 88000, Uzhgorod;

Email: alexander.shuaibov@uzhnu.edu.ua

ing hydrogen. In order to simplify the design of the reactor, it is important to replace the generator of aluminum dust by producing microdroplets of aluminum by exploding microtips on the surface of aluminum electrodes in a strong electric field of a nanosecond discharge (formation of ectons^[3]). Moreover, it is also important to establish the type of nanostructures of aluminum oxide and obtain it in the form of a thin nanostructured film.

In^[4,5], the electrical and optical characteristics of a spark discharge are given, the current and voltage of which had an oscillatory form in the microsecond range. The discharge was ignited between aluminum and graphite electrodes in air and was investigated by time-resolved emission spectroscopy. The studies were carried out in the discharge ignition mode far from the overstress of the discharge gap. Vapor of electrode materials entered the plasma as a result of sputtering under the action of a spark discharge (the duration of the current oscillation train was about 25 μ s, and one full oscillation was 5-6 μ s).

Aluminum oxide nanopowders were synthesized by the gas-phase method in^[6]. With this method of nanopowder formation, a drop of molten aluminum was held in vacuum by a high-frequency field and flowed around with an argon and oxygen flow. Aluminum vapors were carried away to a colder zone, where they condensed and oxidized. The obtained aluminum oxide powder with particle sizes of 60 and 15 nm was pressed, annealed in air, and its photo and cathodoluminescence were studied.

In a subnanosecond high-voltage discharge between aluminum electrodes in air, the characteristics of an aluminum plasma at atmospheric pressure were investigated for the ectonic mechanism of aluminum vapor injection into the discharge gap^[7]. The production of vapor of electrode materials was most effective in the absence of matching between the output resistance of the high-voltage modulator and the resistance of the discharge gap. Under these conditions, the deposition of structures based on sputtered copper electrodes 1- 10 in length and 1 μ m in diameter was observed on the walls of the discharge chamber.

We are not aware of any works on the synthesis of nanostructures of aluminum oxide using an overstressed nanosecond discharge of atmospheric pressure with an ectonic mechanism^[3] of injection of aluminum vapor into the plasma of an oxygen-containing gas. The results of such studies of the synthesis conditions and some characteristics of the nanostructures of copper, zinc, and iron oxides are given in our article^[8].

In addition, the plasma parameters of such discharges remain practically unexplored, which does not allow targeted work to optimize this technology for the synthesis of alumina nanostructures using an overstressed nano-

second discharge in nitrogen with a small addition (at the level of 1%) of oxygen.

This work presents the results of studying the conditions for the formation and characteristics of luminescence of nanoparticles of aluminum oxide in the plasma of an overstressed nanosecond discharge of atmospheric pressure in mixtures of nitrogen with oxygen and nitrogen at atmospheric pressure between aluminum electrodes, and also modeling the electron-kinetic coefficients of the plasma and transport characteristics for the mixture under study.

2. Experimental Technique and Conditions

A nanosecond discharge in mixtures of nitrogen and oxygen (mixture composition 100-1) and argon was ignited in a 3-liter dielectric chamber between aluminum electrodes. The diagram of the discharge device is shown in Figure 1. At a distance of 30 mm from the center of the discharge gap, a glass substrate was installed, which served for the deposition of thin films from the products of the sputtering of the electrode material and the products of the destruction of the gaseous medium. The diameter of the aluminum cylindrical electrodes was 5 mm. The radius of curvature of the working end part of the aluminum electrodes was 3 mm. The pressure of the gas mixture and argon was varied in the range of 50 - 202 kPa. The distance between the electrodes was 2 mm. Aluminum vapors were introduced into the discharge gap due to microexplosions of surface irregularities of aluminum electrodes in a strong electric discharge field and the formation of ectons^[3].

To ignite the discharge, high-voltage bipolar pulses with a total duration of 50-100 ns and an amplitude of \pm (20-40) kV were applied to the electrodes.

The discharge was photographed using a digital camera. The distance between the electrodes was used as a scale for determining the plasma volume. At an interelectrode distance of 2 mm, the discharge gap was strongly overstressed. The nanosecond discharge at a pressure of $p = 50$ -202 kPa was rather uniform.

The voltage pulses across the discharge gap and the discharge current were measured using a broadband capacitive divider, a Rogowski coil, and a 6-LOR 04 broadband oscilloscope. The time resolution of this recording system was 2-3 ns. The pulse repetition rate was varied in the range $f = 35$ -1000 Hz. To record the emission spectra of the discharge, an MDR-2 monochromator, a FEU-106 photomultiplier, a dc amplifier, and an electronic potentiometer were used. Plasma radiation was analyzed in the spectral region 200-650 nm. The plasma radiation registration system was calibrated against the radiation of a deuterium lamp in the spectral range of 200-400 nm and a band lamp

in the range of 400-650 nm. The pulse electrical power of the overstressed nanosecond discharge was determined by graphically multiplying the oscillograms of voltage and current pulses. Time integration of the pulsed power made it possible to obtain energy in one electric pulse, which was introduced into the plasma. The experimental technique and conditions are described in more detail in^[8].

Thin films based on the destruction products of aluminum electrodes and oxygen molecules were deposited on glass substrates during 2-3 hours of reactor operation. The resulting films were tested for light transmission in the visible wavelength range. The experimental technique and technique for recording the transmission spectra of the synthesized films are described in^[9].

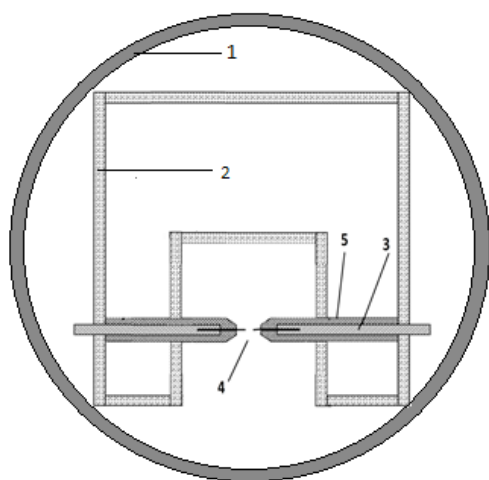

Figure 1. The design of the gas-discharge module: 1 - housing, 2 - fixing the system of electrodes made of plexiglass, 3 - control system for the distance between the electrodes, 4 - electrodes made of aluminum, 5 - insulators made of fluoroplastic

3. Spatial, Electrical and Optical Characteristics

The plasma volume depended on the repetition rate of voltage and current pulses and in the frequency range of 10- 150 Hz it increased from 3 to 30 mm³. The discharge had a diffuse shape in the form of a sphere. The reason for obtaining a diffuse discharge in gases at atmospheric pressure may be the preionization of the discharge gap by a runaway electron beam with a duration of about 130-150 ps, which is formed at high values of the parameter E/N (where: E is the electric field strength, N is the density of particles in the discharge)^[10]. It was experimentally established in^[11] that even when using high voltage pulses with a leading edge duration of about 200 ns, a runaway electron beam with an intensity of only an order of magni-

tude less is formed in the discharge plasma in atmospheric pressure air, even in the same discharge at an air pressure of 13 kPa.

The most typical oscillograms of voltage and current pulses for an overstressed nanosecond discharge between aluminum electrodes in Argon and a mixture of nitrogen with oxygen are shown in Figure 2 and 3. Due to the mismatch between the output resistance of the pulsed high-voltage modulator and the plasma resistance, the voltage pulse had the form of individual spikes with a duration of 7 -10 ns. This mode of ignition of a subnanosecond high-voltage discharge between metal electrodes in the form of a needle and a flat metal plate (or grid), when the total duration of a train of 10 nanosecond voltage pulses was 1-1.5 μ s, was used in^[7] to obtain plasma jets from a material electrodes. It is promising for the deposition of thin metal films on solid substrates of highly dispersed powders based on electrode materials and products of destruction of molecules of a gas medium.

The maximum value of the positive and negative components of current pulses reached 300 A, voltage amplitudes of 30-40 kV. An increase in the argon pressure in the discharge gap to 101 kPa led to an increase in the plasma resistance and an increase in the matching between the output of the high-voltage modulator and the discharge. Therefore, with an increase in the argon pressure from 50 to 101 kPa, the energy input to the plasma in one discharge pulse increased from 226 to 441 mJ.

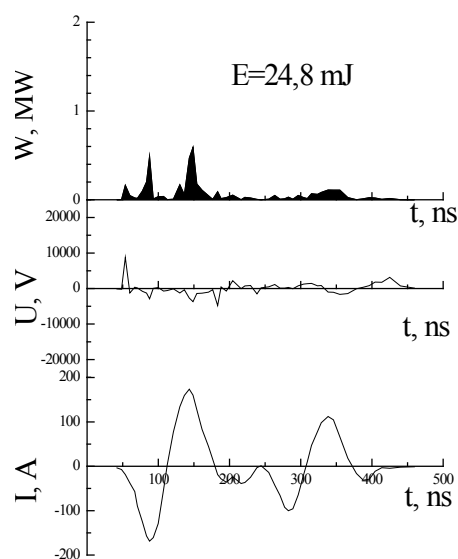

Figure 2. Oscillograms of current, voltage, pulsed power of the discharge, and energy input to the plasma in one discharge pulse at an argon argon pressure of 13.3 kPa

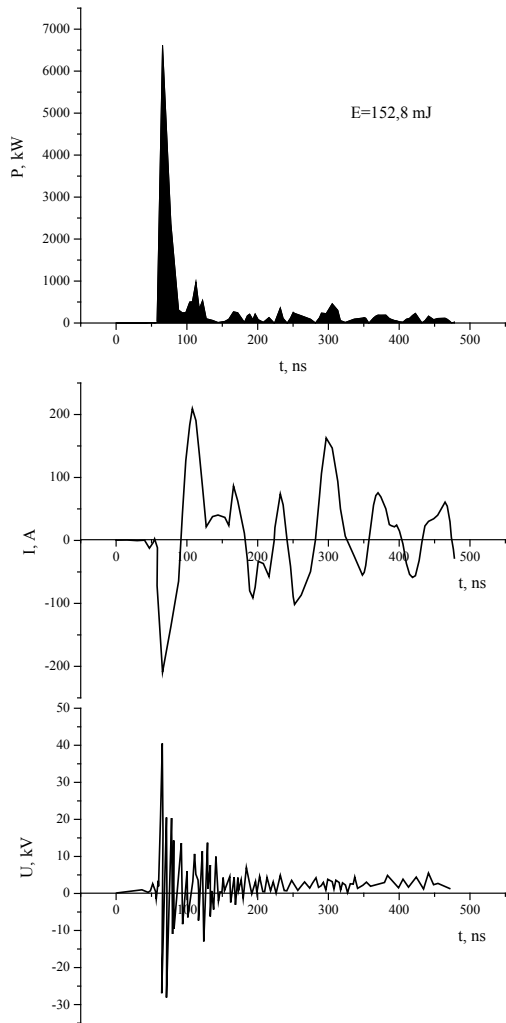

Figure 3. Oscillograms of voltage and current pulses at a pressure of a nitrogen and oxygen mixture of 100 kPa-1 kPa

With an increase in the pressure of the mixture of nitrogen and oxygen (1001) from 50 to 101 kPa, the maximum

value of the pulsed electric power of the discharge increased from 3 to 6.3 MW, and the maximum energy input per pulse increased from 110 to 153 mJ.

Figure 4 and 5 present plasma emission spectra of an overstressed nanosecond discharge between aluminum electrodes in a mixture of nitrogen and oxygen and argon. Experiments with argon, which were carried out in the same pressure range as with air, were carried out in order to demonstrate the absence of emission bands of nanostructures of aluminum oxides in the plasma of inert gases (where, in principle, there are no oxidizer molecules).

It can be seen from Figure 4 and 5 that the emission intensity of the discharge plasma in air at all pressures studied by us exceeds the emission intensity of the spectral lines and discharge bands in argon. In the spectra of plasma radiation based on mixtures of nitrogen and oxygen, a small admixture of aluminum vapor recorded radiation on the transitions of the atom and singly charged aluminum ion, nitrogen oxide radicals and nitrogen molecules, as in the emission spectra of a subnanosecond discharge plasma [7]. In the discharge based on argon, radiation was mainly recorded at the transitions of the atom and ion of aluminum (Table 1).

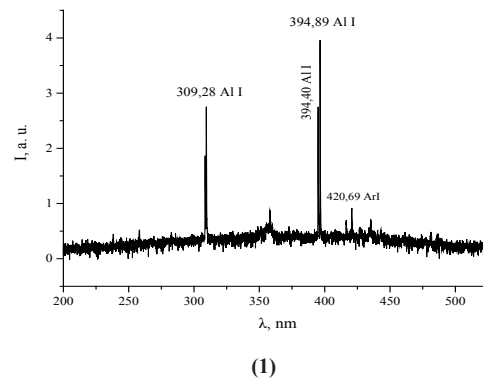

Table 1. The results of decoding the emission spectra of the discharge between the electrodes from aluminum in argon (Figure 4)

Wavelength, nm	Particle	Transition	Terms	Lower energy level, eV	Upper energy level, eV
308.21	Al I	$3s_2(^1S)3p-3s_2(^1S)3d$	$2P^*-2D$	0.000000	4.021485
309.27	Al I	$3s_2(^1S)3p-3s_2(^1S)3d$	$2P^*-2D$	0.013893	4.021651
309.28	Al I	$3s_2(^1S)3p-3s_2(^1S)3d$	$2P^*-2D$	0.013893	4.021485
394.40	Al I	$3s_2(^1S)3p-3s_2(^1S)4s$	$2P^*-2S$	0.000000	3.142722
394.89	Ar I	$3s^23p^5(2P^*_{<3/2>})4s-3s^23p^5(2P^*_{<3/2>})5p$	$2[3/2]^*-2[1/2]$	11.548350	14.687120
396.15	Al I	$3s_2(^1S)3p-3s_2(^1S)4s$	$2P^*-2S$	0.013893	3.142722
415.85	Ar I	$3s^23p^5(2P^*_{<3/2>})4s-3s^23p^5(2P^*_{<3/2>})5p$	$2[3/2]^*-2[3/2]$	11.548350	14.528910
419.83	Ar I	$3s^23p^5(2P^*_{<3/2>})4s-3s^23p^5(2P^*_{<3/2>})5p$	$2[3/2]^*-2[1/2]$	11.623590	14.575950
420.06	Ar I	$3s^23p^5(2P^*_{<3/2>})4s-3s^23p^5(2P^*_{<3/2>})5p$	$2[3/2]^*-2[5/2]$	11.548350	14.499050

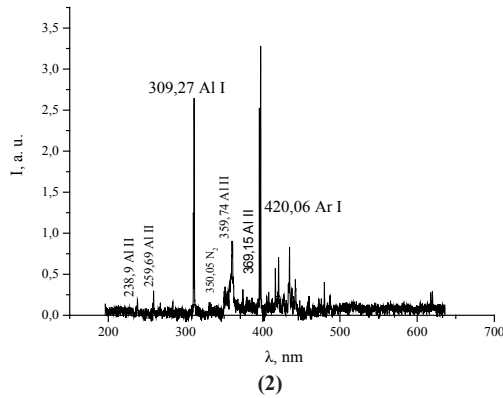

Figure 4. Radiation spectra of overstressed nanosecond discharge at argon pressures 1 - 13.3 kPa, 2 - 101.3 kPa

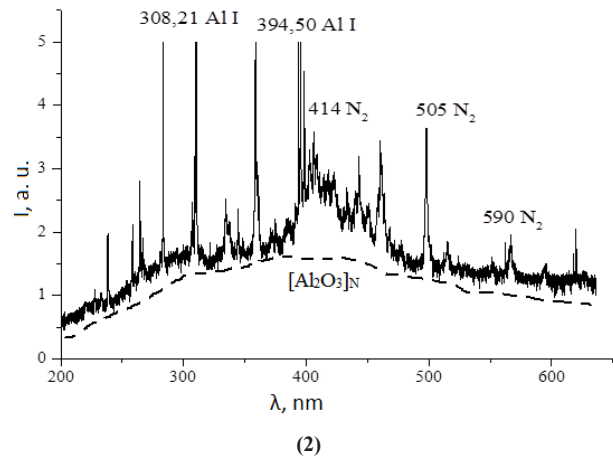
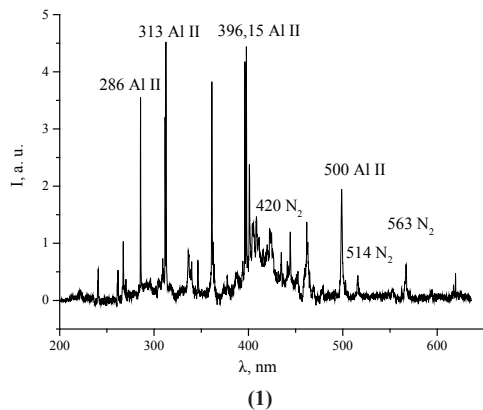

Figure 5. Radiation spectra of overstressed nanosecond discharge between aluminum electrodes in a mixture of nitrogen and oxygen: 13.3 (1) and 101.3 (2) kPa; p (nitrogen) - p (oxygen) = 100-1, dashed line - [Al₂O₃]N - designation of a large cluster or nanoparticle of aluminum oxide

The most intense spectral lines of the atom and singly charged ion of aluminum, which appeared in the spectra of plasma radiation based on mixtures of nitrogen and oxygen, were as follows: (256.8 + 257.5 + 257.5); 265.3; 394.4; 396.2 nm Al I; 236.5; (247.5 + 247.6); 286.9; 622.6; (623.1 + 624.3) nm Al II (Table 2). In addition to the spectral lines of aluminum, intense lines of the atom and singly charged nitrogen ion, as well as molecular

Table 2. Identification of the main spectral lines and emission bands of the plasma of an overstressed nanosecond discharge between aluminum electrodes on a mixture p (nitrogen) - p (oxygen) = 100 - 1 at a pressure of 101.3 kPa

nm	Particle	The configuration of the transition	Term	Lower energy level, eV	Upper energy level, eV
286.84940	Al II	3s3d-3s9p	1D-1P*	13.649400	17.970410
373.39030	Al II	3s4p-3s6s	3P*-3S	13.073080	16.392640
308.21	Al I	3s ₂ (¹ S)3p-3s ₂ (¹ S)3d	2P*-2D	0.000000	4.021485
390.06750	Al II	3s3p-3p2	1P*-1D	7.420707	10.598340
313.58500	Al II	3s4p-3s7s	1P*-1S	13.256460	17.209080
324.16000	Al I	3s2(1S)4d-3s3p(3P*)3d	2D-2F*	5.236819	9.060500
337.13	N ₂	10-0			
344.36400	Al I	3s2(1S)3p-3s3p2	2P*-4P	0.013893	3.613246
348.26300	Al I	3s2(1S)nd-3s3p(3P*)3d	2D-2D*	4.826633	8.385690
364.92040	Al II	3s4p-3s5d	3P*-3D	13.071350	16.467950
365.10870	Al II	3s4p-3s5d	3P*-3D	13.073080	16.467930
387.00490	Al II	3s4f-3s13g	3F*-3G&1G	15.302550	18.505330
394.40060	Al I	3s2(1S)3p-3s2(1S)4s	2P*-2S	0.000000	3.142722
396.15201	Al I	3s2(1S)3p-3s2(1S)4s	2P*-2S	0.013893	3.142722
399.4997	N II				
402.63180	Al II	3s3d-3s6p	1D-1P*	13.649400	16.727880
402.63180	Al II	3s3d-3s6p	1D-1P*	13.649400	16.727880
405.67950	Al II	3s4d-3s15p	1D-1P*	15.472500	18.527850
405.94	N ₂	8-0			

bands of the second positive system of nitrogen, were observed in such a plasma.

In the emission spectra of the plasma of an overstressed nanosecond discharge in mixtures of nitrogen with oxygen and a small admixture of aluminum vapor (Figure 5), broad emission bands were recorded with maxima in the spectral ranges of 390- 440 nm and 290- 300 nm. The highest emission intensity of these bands was observed at a pressure of a mixture of nitrogen and oxygen of 101 kPa. In mixtures based on argon, these bands were absent in the emission spectra of the discharge. Since a significant portion of nitrogen is present in the mixture under study, it is possible to expect the formation of nanostructures of aluminum nitrides in the studied plasma. But a comparison of the broadband emission spectra of the investigated discharge with the characteristic emission spectra of aluminum nitride nanostructures^[12] showed that they are fundamentally different. In^[13], characteristic electroluminescence spectra of anodic aluminum oxide are presented. The spectra in contact with solutions of different electrolytes were recorded at an oxidation current density of 5-15 mA / cm². These spectra were in the form of broad luminescence bands in the spectral range with maxima for different electrolytes in the spectral range of 480-550 nm. Proceeding from this, the most probable source of broadband radiation from the plasma of the discharge under investigation can be nanostructures of aluminum oxide.

In^[6], it was noted that in the photoluminescence spectrum of anion-defect single crystals and nanostructured ceramics based on aluminum oxide, upon excitation of the corresponding samples by radiation with a wavelength of 205 nm, a broad emission band was observed with a maximum at a wavelength of 415 nm. This band coincides with that obtained in the present experiment. It is interpreted as a luminescence band of F centers (transition - 1S - 3P with a maximum emission spectrum at an energy of 3.0 eV and a decay time constant of 36 - 40 ms)^[6,14]. In^[6], the results of studying the cathodoluminescence spectra of nanostructured ceramics of aluminum oxide are also presented. Cathodoluminescence was excited by a pulsed electron beam with a density of 1 A cm⁻², an energy of 180 keV, and a duration of 3 ns. The spectrum of this cathodoluminescence was similar to the spectrum recorded in our experiment at a pressure of 101 kPa for a nitrogen-oxygen mixture. The main one was the emission band with a maximum at wavelengths of 410-420 nm (photon energy 3.0 eV), which was adjacent to a wider short-wavelength band with maxima of the photon energy at 3.4, 3.8, 4.3 eV^[6]. The ultraviolet photo and cathodoluminescence bands of nanostructured aluminum oxide ceramics are associated with the radiation of F + - centers, which are created by oxygen vacancies and

have a relatively short decay time (0.6 - 1.0 μs)^[6,14].

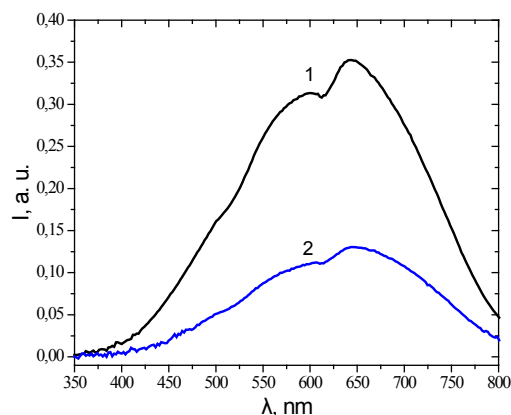

Figure 6. Transmission spectra of films based on copper and aluminum in the spectral region 350-800 nm (band lamp): 1 - clean glass substrate, 2 - film obtained by sputtering aluminum electrodes in a mixture of nitrogen and oxygen 100 - 1 kPa; the repetition rate of voltage and current pulses is 40 Hz, and the sputtering time is 3 h

As can be seen from Figure 6, the resulting film is characterized by weak transmission of radiation in the visible region of wavelengths. According to^[15], films based on nanostructured ceramics made of aluminum oxide are practically opaque in the visible region of the spectrum, their transmission begins to increase in the spectral range of 0.8- 2.0 μm from 1-3 to 25%.

4. Plasma Parameters

The discharge plasma parameters for a mixture of aluminum vapor, oxygen, and nitrogen (component ratio 30: 1000: 100000 Pa) were determined numerically and calculated as total integrals of the electron energy distribution function (EEDF) in the discharge. EEDFs were found numerically by solving the kinetic Boltzmann equation in a two-term approximation. EEDF calculations were carried out using the program^[16]. On the basis of the obtained EEDF, the mean energy of electrons, the mobility of electrons, the specific power losses of the electric discharge, and the rate constants of elastic and inelastic scattering of electrons by aluminum atoms, oxygen molecules and nitrogen molecules were determined, the ratio of which was (30: 1000: 100000) Pa depending on the value of the reduced electric field (the ratio of the electric field strength (E) to the total concentration of atoms of aluminum, molecules of nitrogen and oxygen (N)). The range of changes in the parameter $E / N = 1-1000 \text{ Td}$ ($1 \cdot 10^{-17} - 1 \cdot 10^{-14} \text{ V} \cdot \text{cm}^2$) included the values of the parameter E/N, which were realized in the experiment. The following processes are taken into account in the integral of collisions of electrons with atoms and molecules: elastic scattering of

electrons by aluminum atoms, excitation of energy levels of aluminum atoms (threshold energies 3.1707 eV, 2.9032 eV, 4.1463 eV, 4.2339 eV, 4.1296 eV, 5.1220 eV), ionization of aluminum atoms (threshold energy 6.0000 eV); elastic scattering and excitation of energy levels of oxygen molecules: vibrational (threshold energies: 0.190 eV, 0.380 eV, 0.570 eV, 0.750 eV), electronic (threshold energies: 0.977 eV, 1.627 eV, 4.500 eV, 6.000 eV, 8.400 eV, 9.970 eV, dissociative electron attachment (threshold energy - 4.40 eV) ionization (threshold energy - 12.06 eV); elastic scattering and excitation of energy levels of nitrogen molecules: rotational - threshold energy 0.020 eV, vibrational (threshold energy: 0.290 eV, 0.291 eV, 0.590 eV, 0.880 1.170, 1.470, 1.760, 2.060, 2.350; electronic: 6.170 eV, 7.000, 7.350, 7.360, 7.800, 8.160, 8.400, 8.550, 8.890, 11.03, 11.87, 12.25, 13.00, ionization (threshold energy - 15.60 eV). Data on the absolute values of the effective cross sections of these processes, as well as their dependences on the energies of electrons were taken from the databases [17,18] and works [19].

The electron concentration (N_e) was calculated using the well-known formula [16]:

$$N_e = j / e \cdot V_{dr}$$

where j is the current density in the discharge, e is the electron charge, V_{dr} is the electron drift velocity.

The drift velocity of electrons was determined from the expression [16]:

$$V_{dr} = \mu_e \cdot E$$

where μ_e is the electron mobility, E is the field strength on the plasma.

The field strength on the plasma E was calculated by the formula:

$$E = U_{pl} / d$$

U_{pl} - plasma voltage, d -discharge gap.

The results of a numerical calculation of mean energies of electrons make it possible to determine their temperature in the gas-discharge plasma of the emitter from the well-known formula [16]:

$$\varepsilon = 3/2 \cdot kT$$

where ε is the electron energy, k is the Boltzmann constant, T is the temperature in degrees Kelvin.

The mean energy of the discharge electrons increases almost linearly from 0.2271 eV to 15.93 eV with an increase in the E / N parameter from 1 Td to 1000 Td. For the range of reduced electric field strength 205 Td -820Td, at which experimental studies of the electrical and optical character-

istics of the discharge were carried out, the mean electron energies varied within 5.116-13.41 eV. And their highest energies corresponded to values of 60.57- 241.3 eV.

The results of a numerical calculation of the mean energies of electrons make it possible to determine their temperature in the gas-discharge plasma of the emitter from the well-known formula [16]:

$$\varepsilon = 3/2 \cdot kT$$

where ε is the electron energy, k is the Boltzmann constant, T is the temperature in degrees Kelvin.

It increases from 59345.6 K to 155.556 K when the E / N parameter changes from 205 Td to 820 Td, respectively.

The product of the electron mobility and the total concentration of atoms and molecules of the mixture, as follows from the data of numerical calculations, varies in the range $0.9466E + 24N - 0.6931E + 24N$ (1/m/V/s) with a change in the parameter E / N in the range 205 Td -820 Td, which gives the electron drift velocity values of $1.9 \cdot 10^4$ m / s and $5.7 \cdot 10^4$ m / s, respectively, for the field strength on the plasma of $5 \cdot 10^6$ V / m and $2 \cdot 10^7$ V / m, the value of the electron concentration $1.6 \cdot 10^{20}$ m⁻³ - $1.1 \cdot 10^{20}$ m⁻³ at a current density of $5.1 \cdot 10^6$ A / m² ta $1.02 \cdot 10^7$ A / m² on the surface of the electrode of the radiation source ($0.196 \cdot 10^{-4}$ m²).

In Figure 5 and Table 2 show the lines of atoms and ions of aluminum, nitrogen bands that are present in the spectrum of an overstressed nanosecond discharge between aluminum electrodes in a mixture p (nitrogen) - p (oxygen) = 100 - 1 at a pressure of 101.3 kPa.

Figure 7 shows the dependences of the mean energy of electrons in the plasma of a vapor-gas mixture Al: O₂: N₂ = 30: 1000: 100000 Pa at a total pressure $p = 101.030$ kPa on the reduced electric field strength.

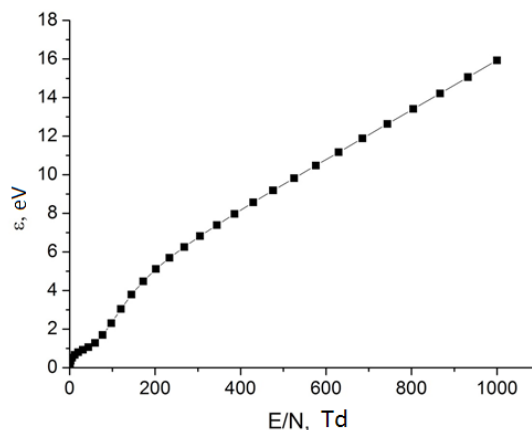

Figure 7. The dependences of the mean energy of electrons in the plasma of a vapor-gas mixture: 1-Al-O₂-N₂ = 30: 1000: 100000 Pa at a total pressure $p = 101.030$ kPa on the reduced electric field strength

The mean energy of discharge electrons for a vapor-gas mixture aluminum-oxygen-nitrogen = 30: 1000: 100000 Pa increases almost linearly from 0.2271 eV to 15.93 eV (Figure 8), with an increase in the reduced electric field strength from 1 Td to 1000 Td. For the range of reduced electric field strength 205 Td - 820 Td, in which experimental studies of the electrical and optical characteristics of the discharge were carried out, the mean electron energies varied within 5.116-13.41 eV for this mixture. Their highest energies corresponded to values of 60.57- 241.3 eV.

Table 3 presents the results of calculating the transport characteristics of electrons: mean energies in ϵ , temperature T K, drift velocity V_{dr} , and the concentration of electrons for a mixture of aluminum vapor with oxygen and nitrogen.

Table 3. Transport characteristics of plasma of an overstressed nanosecond discharge between aluminum electrodes in a mixture of nitrogen and oxygen: $p = 101.325$ kPa; p (nitrogen): p (oxygen) = 100-1)

E/N, Td	Mixture: - Al-O ₂ -N ₂ = 30: 1000:100000 Pa			
	ϵ , eV	T ⁰ , K	V_{dr} , m/s	N_e , m ⁻³
205	5.116	59345	$1,9 \cdot 10^4$	$1,6 \cdot 10^{20}$
820	13.41	155556	$5,7 \cdot 10^4$	$1,1 \cdot 10^{20}$

The temperature and drift velocities of electrons decrease from 155556 K to 59345 K and from $5.7 \cdot 10^4$ m / s to $1.9 \cdot 10^4$ m / s when the parameter E / N changes from 820 Td to 205 Td, respectively. The electron concentration values increase from $1.1 \cdot 10^{20}$ m⁻³ to $1.6 \cdot 10^{20}$ m⁻³ at a current density of $5.1 \cdot 10^6$ A / m² to $1.02 \cdot 10^7$ A / m² on the surface of the radiation source electrode ($0.196 \cdot 10^{-4}$ m²) for a given mixture.

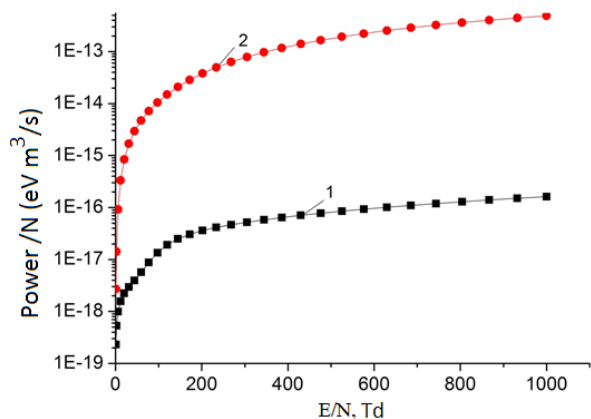

Figure 8. Specific discharge power for elastic (1) and inelastic (2) processes per unit of the total concentration of the mixture on the reduced electric field strength for a mixture of aluminum, nitrogen, oxygen

Table 4. A summary table of the values of the specific power of the discharge for elastic and inelastic processes per unit of the total concentration of the mixture at the experimental values of the reduced electric field strength for the mixture of aluminum, nitrogen, oxygen

E/N, Td	Elastic, Power /N (eV m ³ /s)	Inelastic, Power /N (eV m ³ /s)
205	3,612E-17	3,814E-14
820	1,294E-16	3,622E-13

Figure 8 presents the dependence of the specific powers of discharge losses for inelastic (2) and elastic (1) processes of collisions of electrons with the components of the mixture in a gas-discharge plasma on the reduced electric field strength. An increase in power is observed with increasing values of the reduced electric field, both for inelastic processes and for elastic ones. The specific powers for the reduced electric field strengths at which our experiments were carried out, have the following values: $3.612E-17$ (eV m³ / s) and $3.814E-14$ (eV m³ / s) for a reduced electric field equal to 205 Td, as well as $1.294E-16$ (eV m³ / s) and $3.622E-13$ (eV m³ / s) for a reduced electric field of 820 Td.

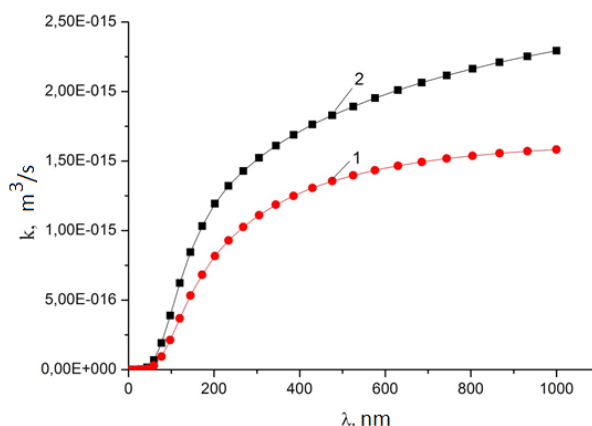

Figure 9. The dependences of the rate constants of collisions of electrons with aluminum atoms on the E / N parameter in plasma on a mixture of aluminum vapor, oxygen and nitrogen = 30: 1000: 100000 Pa at a total pressure of the mixture P = 101030 Pa: 1- excitation of the state of aluminum with a threshold energy 4.13 eV, 2- excitation of the state of aluminum with a threshold energy of 2.9 eV

Figure 9 presents the results of a numerical calculation of the dependence of the rate constants of collisions of electrons with aluminum atoms on the parameter E / N in a mixture of aluminum vapor, oxygen, and nitrogen for a ratio of partial pressures in a mixture of 30: 1000: 100000 Pa at a total mixture pressure P = 101030 Pa for two excitation processes states of aluminum with threshold energies of 4.13 and 2.9 eV, which correspond to the

emission lines that are present in this mixture at 308.21 nm and 394.4 nm. In the range of reduced electric field strength 205 Td - 820 Td, at which experimental studies of the electrical and optical characteristics of the discharge were carried out, the rate constants of these processes are $0.8176E-15$ - $0.1556E-14$ and $0.1194E-14$ - $0.2210E-14$ m^3 / s .

Table 5. A summary table of the values of the rate constants of collisions of electrons with aluminum atoms at experimental values of the E / N parameter in plasma on a mixture of aluminum, oxygen and nitrogen vapors = 30: 1000: 100000 Pa at a total mixture pressure P = 101030 Pa

E/N, Td	394.4 nm	308.21 nm
205	0.1194E-14	0.8176E-15
820	0.2210E-14	0.1553E-14

5. Conclusions

Thus, it has been established that the plasma of an overstressed nanosecond discharge between aluminum electrodes at pressures of a mixture of nitrogen and oxygen (100-1) 50-101 kPa, a pulsed discharge power of 3-6.3 MW and an energy input of 110-153 mJ in one pulse is a source of luminescence nanoparticles of aluminum oxide in the form of a wide band, which is in the spectral range of 200-600 nm; during the deposition of the destruction products of electrodes and air molecules in plasma on a glass substrate, films based on aluminum oxides were obtained, which are characterized by low transparency in the visible region of the spectrum.

Numerical modeling of plasma parameters has established that for the range of reduced electric field strength 205 Td - 820 Td, at which experimental studies of the electrical and optical characteristics of the discharge were carried out, the mean electron energies varied within 5.116-13.41 eV, and their highest energies corresponded to values of 60.57- 241.3 eV. The value of the electron concentration was $1.6 \cdot 10^{20} m^{-3}$ - $1.1 \cdot 10^{20} m^{-3}$ at a current density of $5.1 \cdot 10^6 A / m^2$ and $1.02 \cdot 10^7 A / m^2$ on the surface of the electrode of the radiation source ($0.196 \cdot 10^{-4} m^2$). The excitation rate constants for two processes of excitation of the states of aluminum with threshold energies of 4.13 and 2.9 eV, which correspond to the emission lines that are present in this mixture at 308.21 nm and 394.4 nm in the range of reduced electric field strength 205 Td - 820 Td, at which experimental studies of electric and optical characteristics of the discharge were carried out are as follows $0.8176E-15$ - $0.1556E-14$ and $0.1194E-14$ - $0.2210E-14$ m^3 / s .

The specific powers for the reduced electric field strengths at which our experiments were carried out had the following values: $3.612E-17$ ($eV m^3 / s$) and $3.814E-14$ ($eV m^3 / s$) for a reduced electric field equal to 205 Td, as well as $1.294 E-16$ ($eV m^3 / s$) and $3.622E-13$ ($eV m^3 / s$) for the value of the reduced electric field equal to 820 Td.

References

- [1] Biturin V.A., Efimov A.V., Grigorenko A.V., Goryachev S.V., Klimov A.I., Chinnov V.F. Plasma stimulation of aluminum combustion in water vapour. *Modern science*, 2011, 2(7): 47-51. Available online at: [http://modern.science.triacon.org/en/issues/2011/files/2011_2\(7\)_8.html](http://modern.science.triacon.org/en/issues/2011/files/2011_2(7)_8.html)
- [2] Biturin V.A., Grigorenko A.V., Efimov A.V., Klimov A.I., Korshunov O.V., Kutuzov D.T., Chinnov V.F. Spectral and kinetic analysis of a gas-discharge heterogeneous plasma in the flow of an Al, H₂O, Ar mixture. *High Temperature*, 2014, 52(1): 3-13. Available online at: <https://elibrary.ru/item.asp?id=21866675>
- [3] Mesyats G. A. Ecton- Electron Avalanche from metal. *Usp. Fizich. Nauk*, 1995, 165(6): 601-626.
- [4] Walters J. P., Malmstadt H.V. Emission Characteristics and Sensitivity in a High-Voltage Spark Discharge. *Analytical Chemistry*, 1965, 37(12): 1484-1503. Available online at: <https://pubs.acs.org/doi/abs/10.1021/ac60231a010>
- [5] Walters J. P. Source Parameters and Excitation in a Spark Discharge. *Applied Spectroscopy*, 1972, 26(1): 1484-1503. Available online at: <https://www.osapublishing.org/as/abstract.cfm?uri=as-26-1-17>
- [6] Kortov V.S., Ermakov A.E., Zatsepin A.F., White M.A., Nikiforov S.V. et al. Features of luminescent properties of nanostructured aluminum oxide, *Solid State Physics*, 2008, 50(5): 916-920. Available online at: <https://link.springer.com/article/10.1134/S1063783408050259>
- [7] Beloplotov D.V., Tarasenko V.F., Lomaev M.I. Luminescence of aluminum atoms and ions in a repetitively pulsed discharge initiated by runaway electrons in nitrogen. *Optics of the atmosphere and ocean*, 2016, 29, 2: 96-101. Available online at: <https://www.sibran.ru/upload/iblock/f31/f310891d-5d0661a5c8090d5dbeddf328.pdf>
- [8] Shuaibov A.K., Minya A.I., Gomoki Z.T., Danilo V.V., Pinzenik P.V. Characteristics of a High-Current Pulse Discharge in Air with Ectonic Mechanism

- of Copper Vapor Injection into a Discharge Gap. *Surface Engineering and Applied Electrochemistry*, 2019, 55(1): 65-90. Available online at: <https://www.springerprofessional.de/en/characteristics-of-high-current-pulse-discharge-in-air-with-ecto/16681528>
- [9] Holovey V.M., Popovych K.P., Prymak M. V., Birov M.M., Krasilinets V.M., Sidey V.I. X-ray induced optical absorption in $\text{Li}_2\text{B}_4\text{O}_7$ and $\text{Li}_2\text{B}_4\text{O}_7:\text{Cu}$ single crystals and glasses. *Physica B*, 2014, 450: 34-38. Available online at: <https://www.sciencedirect.com/science/article/abs/pii/S0921452614004578>
- [10] Runaway electrons preionized diffuse discharge / Ed. by V.F. Tarasenko. New York: Nova Science Publishers Inc., 2014: 578.
- [11] Beloplotov D. V., Tarasenko V. F. On the influence of a cathode shape on the parameters of current pulses of runaway electron beams in a gas discharge when applying voltage pulses with a rise time of 200 ns, *Journal of Physics*: 2019, 1393(012004): 7. Available online at: <https://iopscience.iop.org/article/10.1088/1742-6596/1393/1/012004>
- [12] Silvera E., Freitas I.A., Glembocki O.J., Slack G.A., Schowalter L.J. Excitonic structure of bulk AlN from optical reflectivity and cathodoluminescence measurements. *Phys. Rev.*, 2005, 71, (10): 041201-041204. Available online at: <https://journals.aps.org/prb/abstract/10.1103/PhysRevB.71.041201>
- [13] Egorov A.E., Chernyshev V.V. Electroluminescence spectra of anodic alumina in various electrolytes. *Bulletin of Voronezh State University. Series. Physics mathematics*, 2005(2): 8-10.
- [14] Gasenkova I.V., Mukhurov N.I., Vakhioh Ya.M. Optical properties of anodized aluminum substrates as a basis for threshold detectors. *Reports of BSUIR*, 2016, 2(96): 114-118.
- [15] Seredin P.V., Goloshchapov D.L., Lukin A.N., Bondarev A.D., Lenshin A.S. et al. Structure and optical properties of Al_2O_3 thin films obtained by reactive plasma sputtering on GaAs substrates (100). *Physics and technology of semiconductors*, 2014, 48(11): 1564-1569. Available online at: <https://link.springer.com/article/10.1134%2FS1063782614110256>
- [16] BOLSIG+ Electron Boltzmann equation solver. Available online at: <http://www.bolsig.laplace.univ-tlse.fr>.
- [17] Content and usage of the archive Available online at: <http://www.ioffe.ru/ES/Elastic/data2.html>
- [18] Electron-Impact Cross Sections for Ionization and Excitation Database . Available online at: https://physics.nist.gov/cgi-bin/Ionization/ion_data.php?id=Al&ision=I&initial=&total=Y
- [19] Shimon L.L. Influence of autoionization states on the population of energy levels of atoms of the aluminum subgroup. *Scientific Bulletin of UzhNU. Physics Series*, 2007, 20: 56-61.